

K25 Level Switch

for High Pressure environments with 4÷20 mA analog temperature output

Application Description

The optical level switch has been designed for use in level monitoring applications for the control of oil or liquid CO₂ for transcritical or sub-critical application.

The switch has no moving parts, thus it is particularly suited for monitoring critical media where high reliability is needed.

The sensor provides two outputs:

- the first one – digital - indicates if the liquid is present or absent,
 - the second one – analogical – is proportional to the temperature read.
- It combines the Temperature Management with the high pressure resistance up to 150 Bar.



Operating Principle

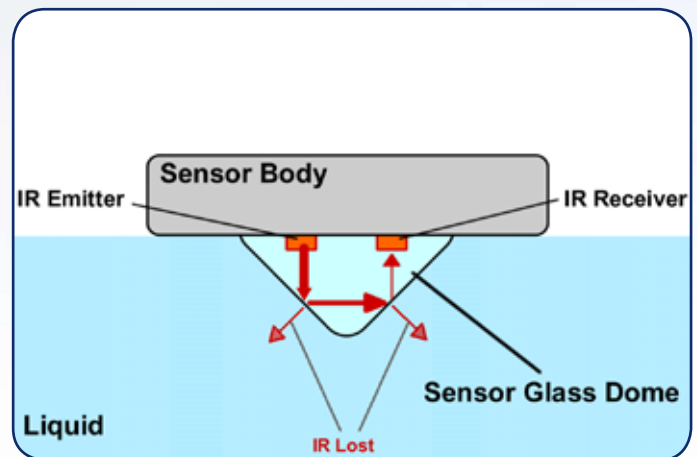
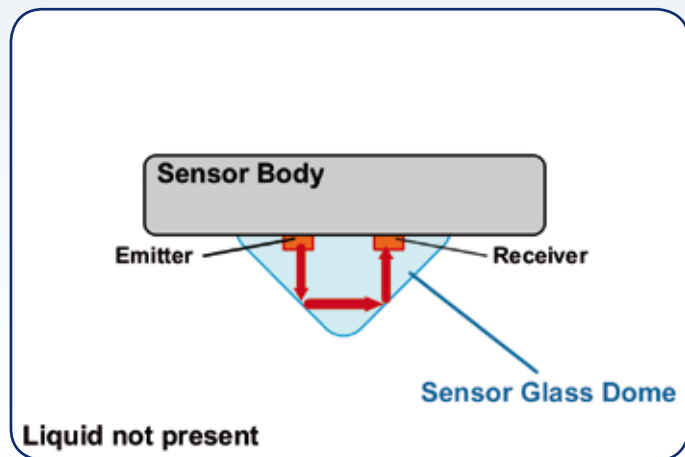

The sensors contains an infrared-ray emitter and an optical receiver. In air (liquid not present), all the light emitted is reflected - internally - by the dome and then redirected to the receiver. When the liquid reaches the sensor dome, a big amount of the light emitted is lost in the liquid and the sensor senses its presence.

K25 Level Switch for High Pressure environments with 4÷20 mA analog temperature output

Technical Data

OPERATION MODE	Detect liquid presence with contact
REPEATABILITY	± 2 mm.
BODY MATERIALS	Stainless Steel
SENSIBLE DOME	Glass
ELECTRONIC PROTECTIONS	Transient over voltage, reverse polarity
MAX. TEMPERATURE RANGE	From -40°C up to +125°C
STORAGE TEMPERATURE	From -40°C up to +125°C
SUPPLY VOLTAGE	24 VDC ± 10%
SUPPLY CURRENT (LEVEL SECTION)	20mA max.
OUTPUT TYPE	NPN
DC OUTPUT LOAD CURRENT	up to 50 mA max
OUTPUT MODE	Output Normally Open or Closed in air
TEMPERATURE OUTPUT	Analogical from 4 to 20 mA
DELAY TIMES	Customizables depending on application needs
MAX PRESSURE	up to 150 bar

Mechanical Dimensions

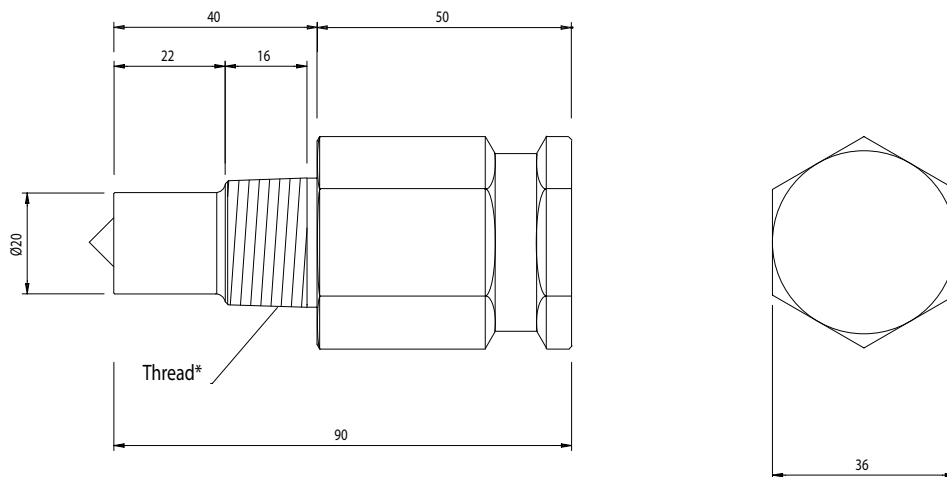

Quotes in mm

*Available threads: 3/4" NPT, 1" 1/8 18 UNEF.



Via Emilia Ovest, 1179 - 41123 Modena - Italy
Tel. +39 059 375498 - Fax +39 059 376294
info@teklab.biz - www.teklab.biz